

WPOOL

Pool Pumps

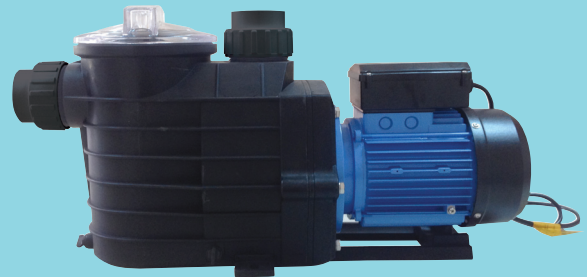

FEATURES

- The wet end is made by High strength engineering plastic and attach with wear-resisting mechanical seal
- Self-priming functions. The max suction is 1.5 m
- 90 frame. Two speed motor is optional.
- With low noise standard motors; single phase motor installation TI thermal protector
- Motor adopts high temperature resistant bearing that be long life, reliable and durable.
- Liquid absolutely separate with shaft to keep more safe and reliable
- Air-switch/pneumatic switch is optional
- Insulation class F, Protection IPX5

APPLICATION

Suitable for the hot spring baths, large swimming pools, water treatment facilities etc.

OPERATING CONDITIONS

Medium temperature: 5...+50 °C

Environmental Temperature: less than 40 °C

Max. Operating pressure: 0.3 MPa

WPOOL

Pool Pumps

Performance Tables and Dimensions

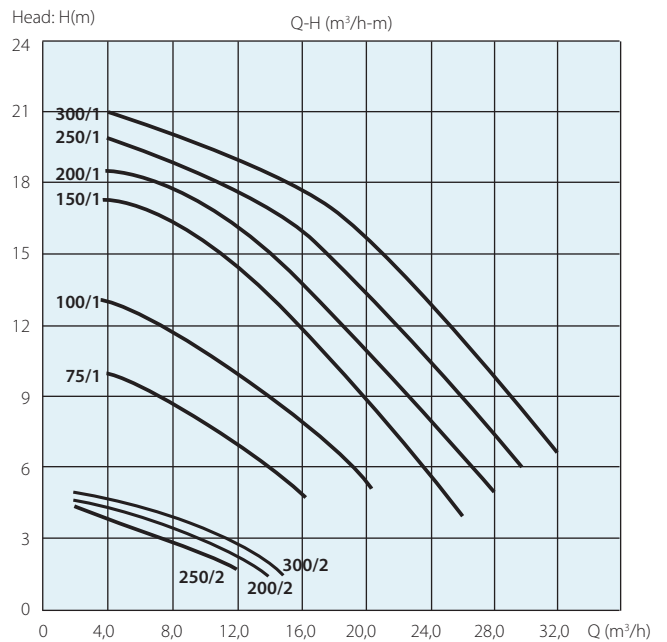
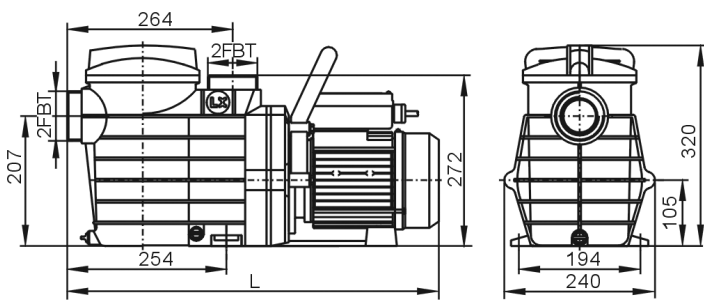

Model	Power P1 (kW)	L	Fitting Size
WPOOL 75/1	0,55	593	60.3 or 63
WPOOL 100/1	0,75	593	
WPOOL 150/1	1,1	593	
WPOOL 200/1	1,5	593	
WPOOL 250/1	1,85	593	
WPOOL 300/1	2,2	609	
WPOOL 200/2	0,35 (Low Speed)	628	
	1,5 (High Speed)	628	
WPOOL 250/2	0,4 (Low Speed)	628	
	1,85 (High Speed)	628	
WPOOL 300/2	0,45 (Low Speed)	628	
	2,2 (High Speed)	628	

Model	P1 (kW)	Q(m³/h)	4	8	12	16	20	22	24	26	28	30	32
WPOOL 75/1	0,55	H(m)	10	8	7	5							
WPOOL 100/1	0,75		13	11	10	7	5						
WPOOL 150/1	1,1		17	15	13	12	10	9	7	6			
WPOOL 200/1	1,5		18,5	18	16,5	14	11	9,5	8	6	5		
WPOOL 250/1	1,85		20	19	18	16	13,5	12	10,5	9	7	6	
WPOOL 300/1	2,2		21	20	19	18	15,5	14,5	13	11,5	10	8,5	6,5

Model	P2 (kW)	Q(m³/h)	2	4	6	8	10	12	14	15
WPOOL 200/2	0,35	H(m)	4,5	4	3,5	3	2,5	1,8		
WPOOL 250/2	0,4		4,7	4,5	4	3,5	3	2,5	1,5	
WPOOL 300/2	0,45		5	4,8	4,5	4	3,5	3	2	1,5